

FOAM TRAILER

HARDWARE



Features

Trailer design offers extreme mobility

Single, dual or multiple polypropylene tote design available

Metal concentrate tank or custom design trailers also available

Totes containers are manufactured of high density polyethylene and are incased in a rigid galvanized steel grid. Available in 265 gallon (1003 litre) and 320 gallon (1211 litres) capacities

Standard size metal tanks available in sizes of 500, 750, and 1000 gallons (1893, 2839, 3785 litres).

Note: Custom designed sizes available to meet customer needs

Trailer constructed of all welded steel

High flow capacity

Self-educing nozzle

Accessory options available including NFPA 1901 compliance

Meet DOT highway requirements



Description

The SOLBERG® Foam Trailer consists of the following: A complete mobile package meeting all applicable NFPA standards consisting of a trailer constructed with frame, wheels, and axles capable of carrying the total charged weight of the trailer assembly and the foam concentrate. The trailer frame includes a tongue jack, electrical connections, NFPA 1901 lighting package (optional), reflective striping, rear mud flaps, and rear stabilizer jacks. The foam system

can utilize either of two foam storage vessel designs: polyethylene tote(s), either single, dual, multiple or a rigidly constructed metal foam tank. The foam monitor is capable of delivering up to 1000 gpm (3785 lpm) of foam solution at a pressure of 100 psi (7.0 bar). The monitor connections are up to 3.0" (76 mm). The self-educing monitor nozzle is capable of delivering up to 1000 gpm (3785 lpm) at 100 psi (7.0 bar).

SOLBERG is a member of PERIMETER SOLUTIONS, a global producer of leading fire retardant, gel and foam brands with a singular purpose: revolutionize the course of fire suppression technology with safer, more effective and more sustainable solutions. Together, we are Moving Industries Forward by Redefining Fire Suppression. www.solbergfoam.com

Application

The SOLBERG Foam Trailer is designed to provide quick, mobile foam fire protection for hazards consisting of flammable liquids. These types of hazards can be defined as tank farms, loading racks (both truck and rail), chemical processing plants, and marine off loading/on loading terminals. The trailer storage vessel, either tote(s) or metal tank, provides a large capacity supply of foam concentrate. The pre-piped monitor and nozzle allow for the foam system to be put into action very rapidly. The SOLBERG Foam Trailer greatly increases the firefighting ability of industrial, municipal, and military fire emergency responders.

Specifications

Trailer Frame

The trailer frame shall be constructed of all welded steel. No bolts, screws, or rivets shall be used in the construction of the frame. The trailer framework shall be constructed of 4.0" x 2.0" x 0.125" (102 mm x 51 mm x 3.2 mm) wall steel tubing. The cross members shall be notched at their ends to fit inside of the outer frame channels. Cross members shall be positioned to maximize support for the foam totes, monitors, and plumbing. Two lengths of 4.0" (102 mm) channel shall be welded diagonally between the coupler and the front corners of the frame. The front of the trailer

(monitor operators position), shall be covered with 0.125" (3.2 mm) embossed aluminum diamond plate. Mounting provisions shall be provided for the foam tank(s). The trailer shall be equipped with 2-5/16" coupler, adjustable front jack, two rear stabilizer jacks, and full light package for highway use.

Axles

The axles shall be rated a minimum of 3500 lb (1588 kg) load rating each. The axles shall be bolted to the frame utilizing Grade 8 bolts. The axles shall consist of torsion bar suspension and independent wheel movement to provide maximum shock absorption and proper handling.

Brakes

The trailer assembly shall contain an electric brake system.

NFPA Lighting Package (optional)

The trailer shall contain a light package that meets the minimum warning light and actuation requirements of NFPA 1901 Fire Apparatus Standard (current edition).

Hose Bins

Two hose bins shall be provided. Each located above each of the trailer fenders.

Tote Tank

Each tote foam storage container(s) shall be sized to hold 265 gallons (1003 litres) (or optional 320 gallon (1211 litres)) of foam concentrate. The tote shall be constructed of high

density polyethylene. The tote shall be enclosed by a galvanized steel base and rigid, welded galvanized tubular steel grid.

Metal Tank

The optional metal foam storage container shall be sized to hold 500, 750, or 1000 gallons (1893, 2839, 3785 litres) of foam concentrate. The metal tank shall be constructed of painted steel, or stainless steel, of sufficient gauge. Custom designed sizes shall be available to meet customer needs.

Foam Tank Connection

Foam connection hoses shall be constructed of 1.5" (38 mm) or 2.0" (50 mm) suction hose to allow foam flow. Cam and groove couplings shall be used to enable quick connection and disconnection of the foam concentrate hoses.

Foam Monitor

The 3.0" (76 mm) monitor inlet shall be provided at the front of the trailer. The inlet shall terminate with a 3.0" (76 mm) or 4.0" (102 mm) 4-bolt 150# flange. The discharge shall be gated with a 3.0" (76 mm) quarter turn ball valve. The valve controller shall be located on the valve. The monitor shall be bolted directly to the 3.0" flange. Threaded 0.25" NPT ports shall be provided for drain valve and pressure gauge. Maximum flow capacity of 1000 gpm (3785 lpm) shall be based on monitor type selected.

Self-Educting Foam Nozzle

Fixed gallonage combination, fog, straight stream, self-educting, constant gallonage foam nozzle shall be available with a flow rate up to 1000 gpm (3785 lpm) at 100 psi (7.0 bar) (specify) and user selected foam proportioning ratios of 0.5%, 1.0%, 3.0%, or 6.0%. Nozzle shall be hard coat anodized aluminum alloy or brass. Nozzle shall include

an industrial hard grade UV resistant 1.5" (38 mm) concentrate pick-up hose with cam lock connection to the nozzle foam inlet and a UV resistant front rubber bumper and halo ring for pattern adjustment.

Finish

The trailer shall be prepared and finished with SOLBERG blue or red enamel finish.

Options

Contact SOLBERG Technical Services for options on monitors, hoses, and other trailer equipment.

Dimensional Information

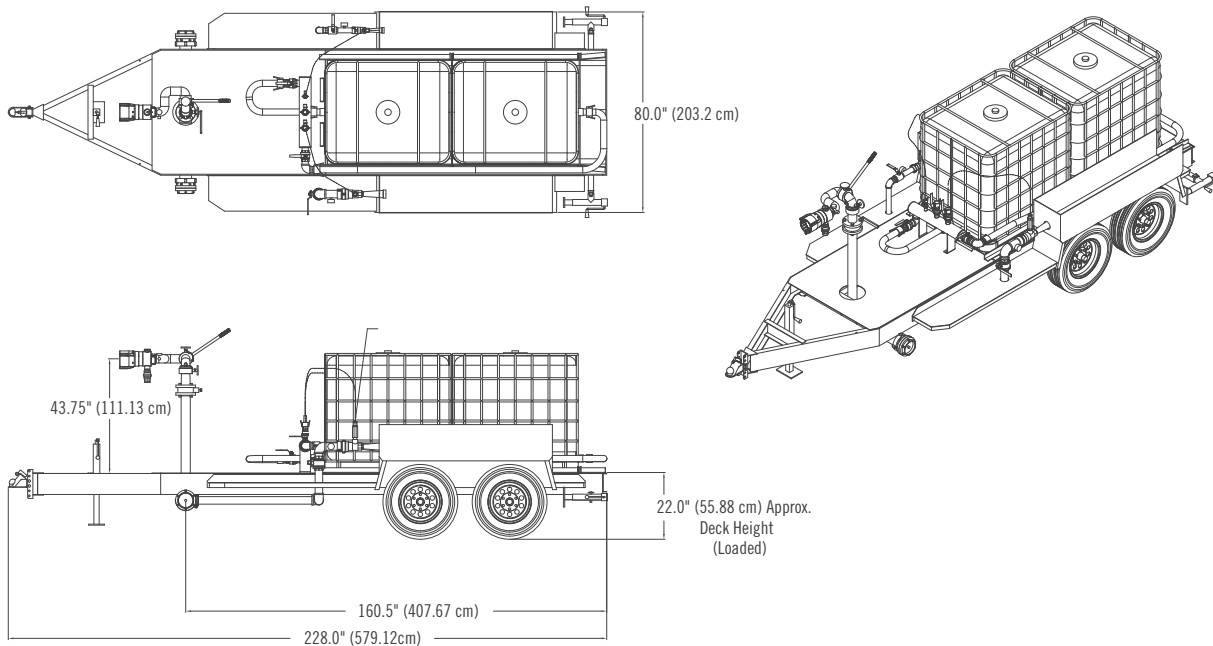

Note: Drawings are conceptual and representative in nature. Dimensions are approximates and will vary depending on model and options selected at time of purchase.

ORDERING INFORMATION

Contact Solberg Technical Services Department for options, pricing and delivery.





NOTICE: Perimeter Solutions makes no representations or warranties as to the completeness or accuracy of the information included herein. The information contained herein is not intended to provide regulatory, legal or expert advice relating to the products, its application or uses. Nothing contained herein is to be construed as a recommendation to use any product, process, equipment or formulation in conflict with any industrial property or intellectual property rights, and Perimeter Solutions makes no representation or warranty, express or implied, that the use thereof will not infringe on any industrial property or intellectual property rights. NO REPRESENTATIONS OR WARRANTIES, EITHER EXPRESSED OR IMPLIED, OF MERCHANTABILITY, FITNESS FOR A PARTICULAR PURPOSE OR OF ANY OTHER NATURE ARE MADE HEREUNDER WITH RESPECT TO THE INFORMATION CONTAINED HEREIN.

SOLBERGFOAM.COM

FORM NUMBER F-2012003-4

COPYRIGHT © 2014. ALL RIGHTS RESERVED.
SOLBERG IS A TRADEMARK OF PERIMETER SOLUTIONS OR ITS AFFILIATES.

AMERICAS

PERIMETER SOLUTIONS, LP
1520 Brookfield Avenue
Green Bay, WI 54313
USA
Tel: +1 920 593 9445

EMEA

PERIMETER SOLUTIONS, LP
Poligono de Baiña, Parcela 23
33682 Mieres (Asturias)
Spain
Tel: +34 985 24 29 45

ASIA PACIFIC

PERIMETER SOLUTIONS, LP
3 Charles Street
St. Marys NSW 2760
Australia
Tel: +61 2 9673 5300