

FOAM CHAMBERS

HARDWARE



Features

Available in four size ranges

Equipped with an inspection opening on the cover plate

Minimum operating pressure 40 psi (3 bar), maximum operating pressure 100 psi (7 bar)

One-piece welded chambers are available for installations not requiring vapor seal

Description

SOLBERG® Foam Chambers are NFPA-11 Type II air aspirating foam discharge devices that provide protection for open top floating and cone roof flammable liquid storage tanks. Foam chambers are a combination of a foam mixing chamber and a foam maker with an air inlet. A removable orifice plate is located between the flange inlet and solution pipe flange, and is sized to deliver the required foam solution at a specified pressure. A frangible glass vapor seal located in the foam chamber body prevents product vapors from entering the foam chamber body. The vapor seal will break once the foam solution enters,

filling the foam chamber body with expanded foam. The foam flows to a deflector plate, which directs the foam to the inside of the storage tank wall and fuel surface, only allowing minimum foam submergence and fuel agitation.

Application

SOLBERG Foam Chambers are air-aspirating Type II discharge devices that protect various types of flammable liquid storage tanks including cone roof tanks (with or without internal floaters) and open top floating roof tanks. The foam chambers are typically used with bladder tank systems or balanced pressure pump systems.

Specifications

The foam chamber assembly consists of the body, integral foam maker, orifice, deflector, vapor seal, gaskets and mounting hardware. The foam chamber body is constructed of steel. The inlet fitting is a raised face 150 lb flange, and the outlet fitting is a flat faced 150 lb flange that can be bolted or welded to the storage tank. Foam chamber body has a cover plate with inspection opening for ease of inspection or access to the vapor



seal. Vapor seal is constructed from glass and designed to meet the UL required burst pressure range of 10 - 25 psi (1 - 2 bar). The deflector face can be either solid or split-type and constructed from steel that can be bolted or welded to side of storage tank.

Foam Chambers are prepared and finished with Solberg red or blue enamel finish.

Certifications

Underwriters Laboratories, Inc. (UL) Listed – Standard 162, FM Approved per Approval Standard 5130.

Solberg is a member of THE AMEREX GROUP, an alliance of independent companies with a singular purpose: revolutionize the course of fire suppression technology with safer, more effective, and more sustainable solutions. Together, we are Moving Industries Forward by Redefining Fire Suppression. www.solbergfoam.com

Flow Rates

FM APPROVED

SFS 825 (C = .615)	RE-HEALING RF3, 3% gpm (lpm)	psi (bar)
MAX ORIFICE 0.938	181 (685)	100 (7)
	162 (613)	80 (6)
	143 (541)	60 (4)
MIN ORIFICE 0.625	84 (318)	100 (7)
	75 (284)	80 (6)
	64 (242)	60 (4)
	60 (227)	50 (3)
SFS 1030 (C = .625)	RE-HEALING RF3, 3% gpm (lpm)	psi (bar)
	315 (1192)	100 (7)
	285 (1079)	80 (6)
	245 (927)	60 (4)
MIN ORIFICE 0.875	220 (833)	50 (3)
	156 (590)	100 (7)
	137 (519)	80 (6)
MIN ORIFICE 0.875	120 (454)	60 (4)
	95 (360)	40 (3)

SFS 1240 (C = .635)	RE-HEALING RF3, 3% gpm (lpm)	psi (bar)
MAX ORIFICE 1.875	680 (2574)	100 (7)
	621 (2351)	80 (6)
	525 (1987)	60 (4)
MIN ORIFICE 1.125	251 (950)	100 (7)
	222 (840)	80 (6)
	194 (734)	60 (4)
	164 (621)	40 (3)
SFS 1660* (C = .650)	gpm (lpm)	psi (bar)
	680 (2574)	100 (7)
	621 (2351)	80 (6)
	525 (1987)	60 (4)
MIN ORIFICE 1.125	251 (950)	100 (7)
	222 (840)	80 (6)
	194 (734)	60 (4)
	164 (621)	40 (3)

*Note: * non-UL Listed, non-FM Approved*

Flow Rates

UL LISTED

SFS 825 (C = .615)	CONCENTRATE	FLOW RANGE MIN.ORIFICE 0.625 - MAX. ORIFICE 0.938
	RE-HEALING RF3, 3%	60 - 181 gpm (227 - 685 lpm)
	ARCTIC 1% AFFF	48 - 179 gpm (182 - 678 lpm)
	ARCTIC 3% AFFF	49 - 180 gpm (185 - 681 lpm)
	ARCTIC 1x3% ATC	51 - 84 gpm (193 - 318 lpm)
	ARCTIC 3x3% ATC	46 - 180 gpm (174 - 681 lpm)

FLOW RANGE

SFS 1030 (C = .625)	CONCENTRATE	FLOW RANGE MIN. ORIFICE 0.875 - MAX. ORIFICE 1.25
	RE-HEALING RF3, 3%	95 - 315 gpm (360 - 1192 lpm)
	ARCTIC 1% AFFF	94 - 312 gpm (356 - 1181 lpm)
	ARCTIC 3% AFFF	96 - 316 gpm (363 - 1196 lpm)
	ARCTIC 1x3% ATC	N/A
	ARCTIC 3x3% ATC	94 - 312 gpm (356 - 1181 lpm)

FLOW RANGE

SFS 1240 (C = .635)	CONCENTRATE	FLOW RANGE MIN. ORIFICE 1.125 - MAX. ORIFICE 1.875
	RE-HEALING RF3, 3%	164 - 680 gpm (621 - 2575 lpm)
	ARCTIC 1% AFFF	149 - 695 gpm (564 - 2631 lpm)
	ARCTIC 3% AFFF	147 - 720 gpm (556 - 2725 lpm)
	ARCTIC 1x3% ATC	N/A
	ARCTIC 3x3% ATC	150 - 695 gpm (568 - 2631 lpm)

Orifice Plate Sizing

English

$$D = \sqrt{\frac{Q}{29.8 \times C \times \sqrt{P}}}$$

Metric

$$D = \sqrt{\frac{Q}{0.6659 \times C \times \sqrt{P}}}$$

Key

- Q = Flow in GPM
- D = Diameter of Orifice in Inches
- C = Coefficient of Discharge for the Orifice (See C factor above)
- P = Pressure in psi

Dimensional Information

APPROXIMATE DIMENSIONS Inches (Millimeters)

MODEL	A	B	C	D	E	F	G	H	J	K
SFS 825	26.25 (667)	17.00 (432)	5.75 (146)	11.50 (292)	4.50 (114)	7.00 (178)	2.50 (64)	7.50 (191)	.63 (16)	8.00 (203)
SFS 1030	32.13 (816)	19.00 (483)	6.50 (165)	13.00 (330)	6.63 (168)	9.00 (229)	3.00 (76)	9.50 (241)	.75 (19)	9.50 (241)
SFS 1240	35.75 (908)	22.00 (559)	7.75 (197)	15.50 (394)	8.75 (222)	10.00 (254)	4.00 (102)	11.75 (298)	.88 (22)	11.00 (279)
SFS 1660	41.38 (1051)	23.63 (600)	9.50 (241)	19.00 (483)	10.81 (275)	12.00 (305)	6.00 (152)	14.25 (362)	1.00 (25)	12.00 (305)

FOAM CHAMBER

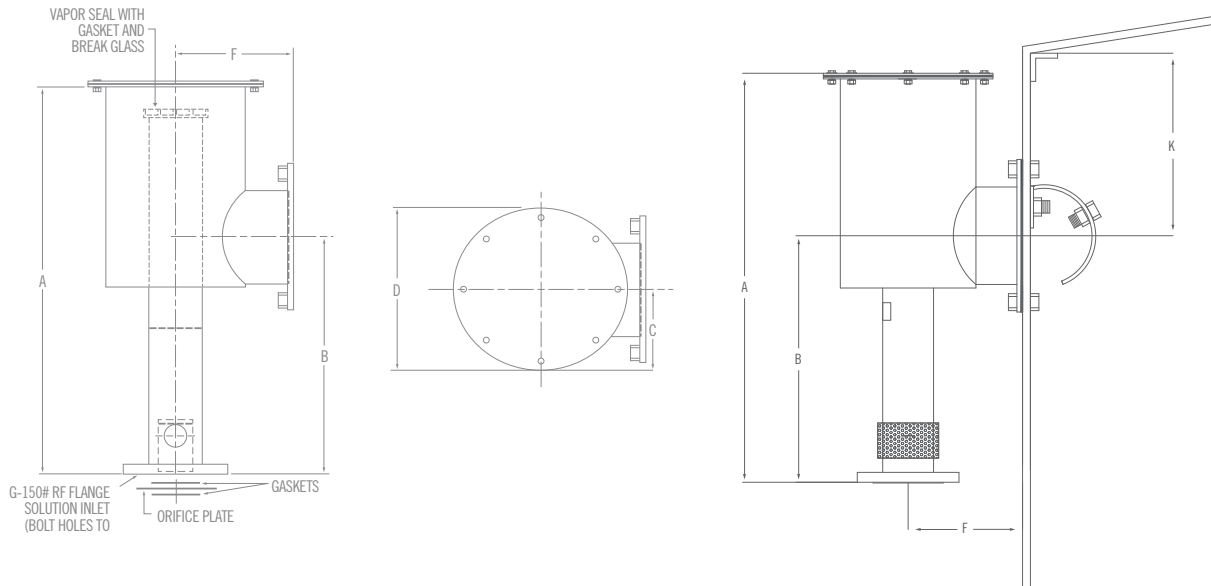

Installation Information

FOAM CHAMBER MOUNTING

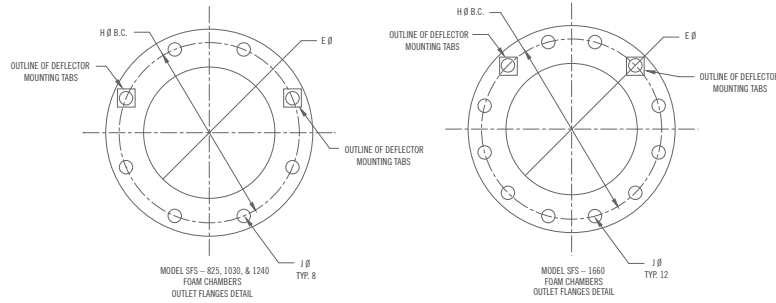

TYPICAL FOAM CHAMBER INSTALLATION

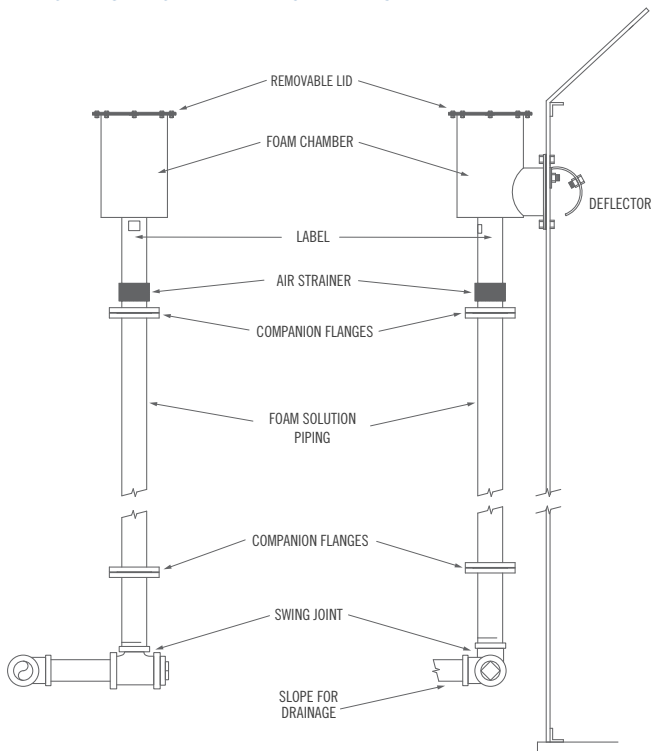

Note: This installation information provides only general guidelines. Each installation may require modifications to meet specific requirements or application(s). The Solberg Company reserves the right to change any portion of this information without notice.

BOLTED WITH PAD, SPLIT DEFLECTOR

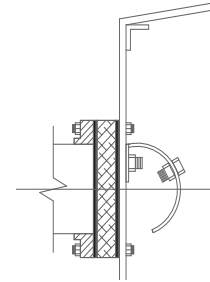

BOLTED WITH PAD, SHALLOW DEFLECTOR

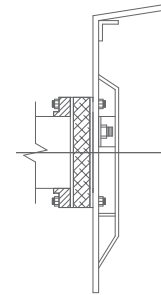

WELDED WITH SPLIT DEFLECTOR

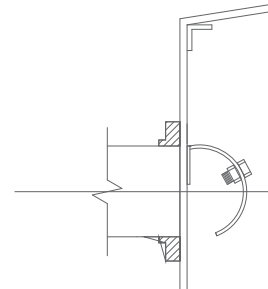

WELDED WITH SHALLOW DEFLECTOR

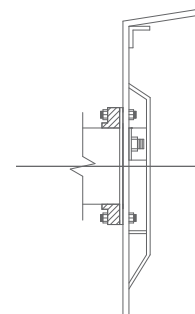

Ordering Information

FOAM CHAMBERS		APPROXIMATE SHIPPING WEIGHT	
PART NO.	DESCRIPTION	lb	kg
32100	Foam Chamber, Model SFS-825, Red Enamel Finish	46	21
32101	Split Deflector Plate, Model SFS-825, Red Enamel Finish	5	2
32102	Solid Deflector Plate, Model SFS-825, Red Enamel Finish	5	2
32103	Foam Chamber, Model SFS-1030, Red Enamel Finish	84	38
32104	Split Deflector Plate, Model SFS-1030, Red Enamel Finish	6	3
32105	Solid Deflector Plate, Model SFS-1030, Red Enamel Finish	6	3
32106	Foam Chamber, Model SFS-1240, Red Enamel Finish	92	42
32107	Split Deflector Plate, Model SFS-1240, Red Enamel Finish	9	5
32108	Solid Deflector Plate, Model SFS-1240, Red Enamel Finish	9	5
32109	Foam Chamber, Model SFS-1660, Red Enamel Finish	163	74
32110	Split Deflector Plate, Model SFS-1660, Red Enamel Finish	12	5
32111	Solid Deflector Plate, Model SFS-1660, Red Enamel Finish	12	5

FOAM CHAMBER - REPLACEMENT PARTS

32120	Vapor Seal Assembly, Model SFS-825	0.50	0.2
32121	Vapor Seal Assembly, Model SFS-1030	0.50	0.2
32122	Vapor Seal Assembly, Model SFS-1240	0.50	0.2
32123	Vapor Seal Assembly, Model SFS-1660	0.50	0.2
32124	Cover Gasket, Model SFS-825	0.25	0.1
32125	Cover Gasket, Model SFS-1030	0.25	0.1
32126	Cover Gasket, Model SFS-1240	0.25	0.1
32127	Cover Gasket, Model SFS-1660	0.25	0.1
32128	Orifice Plate, Model SFS-825	1.00	0.4
32129	Orifice Plate, Model SFS-1030	1.00	0.4
32130	Orifice Plate, Model SFS-1240	1.00	0.4
31131	Orifice Plate, Model SFS-1660	1.00	0.4





SOLBERGFOAM.COM

FORM NUMBER F-2011010-3

COPYRIGHT © 2014 ALL RIGHTS RESERVED.
SOLBERG® IS A TRADEMARK OF THE SOLBERG COMPANY OR ITS AFFILIATES.

AMERICAS

THE SOLBERG COMPANY
1520 Brookfield Avenue
Green Bay, WI 54313
USA
Tel: +1 920 593 9445

EMEA

SOLBERG SCANDINAVIAN AS
Radøyvegen 721 - Olsvollstranda
N-5938 Sæbøvågen
Norway
Tel: +47 56 34 97 00

ASIA-PACIFIC

SOLBERG ASIA PACIFIC PTY LTD
3 Charles Street
St. Marys NSW 2760
Australia
Tel: +61 2 9673 5300